

PRODUCT SUPPORT BULLETIN N

DATE: March 15, 1995

MACHINE: **LS AUTO-LIFT, S/N 500 to Present**

PRODUCTION
DATES: 2/91 through Present

SUBJECT: Main Frame Bending

There have been some instances of the Auto-Lift Main Frame bending and welds cracking. The primary cause of frame failures is improper adjustment of the 1606 400 Pressure Reducing Valve for the Clamp Cylinders. This valve is preset at 1500 psi and used in different applications on Nordco Machines so it cannot be preset for a particular machine. When the valve is installed on an Auto Lift it must be reset to 500 psi. See illustration.

If the 1606 400 Pressure Reducing Valve is not reset the excessive load on the frame will result in a bent frame and cracked welds. The high pressure will also result in excessive wear and short life on the rail clamp components.

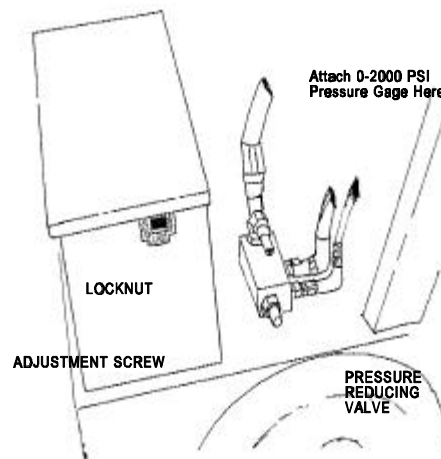

C.J. Kreye
Service Manager