



PRODUCT SUPPORT BULLETIN BULLETIN NO. 318

DATE: **November 10, 2000**

MACHINE: **Model C and 99C**

SERIAL
NUMBER(S): **See Below**

SUBJECT: **Improved Guide Roller Assembly – 96410785**
Heavy-duty Guide Roller Support Upgrade Kit – 98410083
Heavy-duty Guide Roller Upgrade Kit - 98410080

There are several problems that have become evident with the Guide Roller Assemblies used on the Model C and 99C Spiking Machines.

The original Guide Roller Assembly used a 2-piece roller with one central bearing. The nut holding the roller halves in contact with the inner race of the bearing would loosen causing the rollers to become loose on the bolt. Damage to the bearing would result and the rollers would not hold the gun carriage rigid. This causes excessive spike bending.

This problem is solved with an improved **Guide Roller Assembly, p/n 96410785 (standard) or 96410809 (with locking yoke - BNSF)**. The new design uses a one-piece roller with a bearing on each end. This provides better support for roller and is not dependent on the tightness of the nut for support.

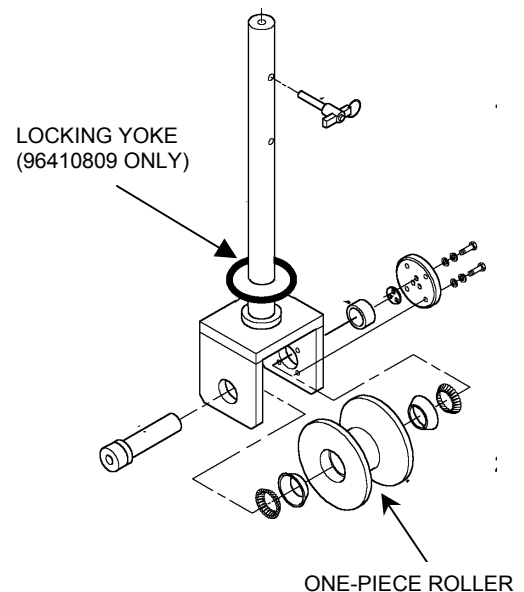

Improved Guide Roller Assy.
96410785 or 96410809

Another problem is the breaking of the Guide Roller Cylinder attachment lug of the Guide Roller Support. A **Heavy-duty Guide Roller Support, p/n 78570007 (LH) and 78570008 (RH)**, with a strengthened cylinder lug has been designed. A new **Guide Roller Cylinder, p/n 28550116**, is required with the Heavy-duty Guide Roller support.

There have also been problems with bending the Spotting Cylinder rods. The cylinder cap-end attachment point was offset from the cylinder centerline and caused this problem. A new **Spotting Cylinder, p/n 28550117** with the attachment point on the centerline has been designed to eliminate this problem. The Heavy-duty Guide Roller Support will accept this re-designed cylinder.

Several different assemblies and kits have been developed to assist our customers in upgrading their machines with all or some of these new components. These assemblies and kits are listed below:

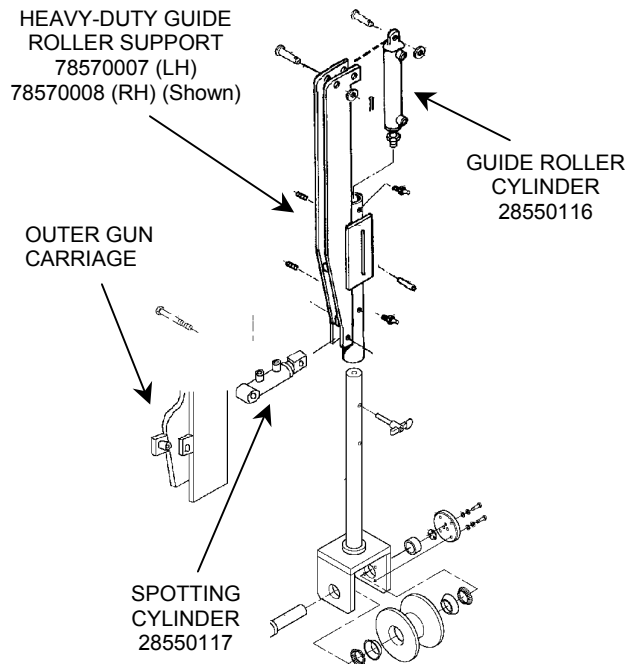

Heavy-duty Guide Roller Support with Improved Guide Roller

**96410785 - Improved Guide Roller Assembly (without Locking Yoke)
S/N 410001 – 410288 (except all BNSF machines)**

Can be installed in about 1 hour in the existing Guide Roller Support.

**98410083 - Heavy-duty Guide Roller Support Upgrade Kit (Guide Rollers NOT Included)
S/n 410001 – 410289 (except Canadian Pacific machines s/n 410257 and up)**

Can be installed in about 4 hours. Requires some welding and cutting of the Outer Gun Carriage Assembly.

**98410080 - Heavy-duty Guide Roller Upgrade Kit (Includes Guide Rollers)
S/n 410001 - 410289 (except all BNSF machines and Canadian Pacific machines s/n 410257 and up)**

Can be installed in about 4 hours. Requires some welding and cutting of the Outer Gun Carriage Assembly.

Kits include all parts necessary to complete the upgrade and installation instructions. The Guide Roller Assemblies are complete assemblies ready to be installed on the machine.

Please contact your NORDCO Representative or the NORDCO Parts Department for pricing and availability.